

Integrated Back-up Battery System

Model: IBBS-24v-3ah-CRT-V



The ***Integrated Back-up Battery System, IBBS***, is an electronic system that combines a Lithium-Iron-Phosphate (Li-Fe-PO₄) battery pack, a charger and switching logic in one convenient package. The IBBS provides an engineered solution to enable an endurance bus for critical loads found in aircraft. It simplifies the wiring and installation of a source of back-up power by integrating all of the key elements into a single enclosure. The ***IBBS*** system provides back-up power to critical electronic loads such as EFIS, GPS, Autopilots and engine monitor systems.

Integral to the IBBS is a lithium-iron-phosphate battery pack and a matched charging system to ensure the battery is properly charged and maintained. The system also includes switching circuitry to provide a stable source of output power during normal and emergency operations. The IBBS system also provides signals to other equipment such as EFIS systems to communicate the operating state of the main aircraft bus as well as the state of the battery.

The IBBS system connects to the standard aircraft power bus and provides an output to critical equipment that require back-up power. Additionally, the IBBS system provides surge and sag protection for connected equipment, allowing operation of critical equipment during engine starting.

The IBBS system is suitable for use with equipment such as Garmin and Avidyne navigators, G3X series of avionics, Grand Rapids Technologies EFIS systems, Advanced Flight Systems EFIS, Dynon EFIS, Aspen Avionics and MGL EFIS, TruTrak Autopilots and EFIS, Trio Autopilots, JPI and EI engine monitors, SureFly electronic ignitions, Lycoming EIS electronic ignitions, and ElectroAir electronic ignitions.

The IBBS must be installed using the current aircraft standards and practices as detailed in AC 43.13-2A/1B.

IBBS products are protected by US Patent 8,189,305

Table of Contents

Limitations	pg. 3
Installation Information:	pg. 3-6
General Product information:	pg. 7
Battery Capacity details:	pg. 8
Normal Product Operation:	pg. 9
Emergency Operation:	pg. 9
Instructions for Continued Airworthiness:	pg. 10-12
Specifications	pg. 13
Functional performance, environmental testing	pg. 14
Environmental Qualification Statement	pg. 15
Connector Pin-out	pg. 16
Mounting plate drawing	pg. 17
General Wiring diagram	pg. 18
Example Wiring diagrams	pg. 19-20
Support and Warranty information	pg. 21

Limitations:

This article meets the minimum requirements of technical standard order (TSO) C179b. Installation of this article requires separate approval.

The conditions and tests for TSO approval of this article are minimum performance standards. It is the responsibility of those installing this article either on or within a specific type or class of aircraft to determine that the aircraft installation conditions are within the TSO standards which include any accepted integrated non-TSO function standards. TSO articles and any accepted integrated non-TSO functions(s) must have separate approval for installation in an aircraft. The article may be installed only according to 14 CFR Part 43 or the applicable airworthiness requirements.

This article may not be installed as the sole source of power for an instrument or avionic device that has no other redundancy in the aircraft. (i.e., If an aircraft has one and only one vhf radio, it must have an additional source of power beside the IBBS system to qualify for installation.)

See page 13 for Performance Specifications and potential limitations and ratings under various conditions, including environmental and application installations. See Item 3 below for installation location limitations.

Installation Information:

1. **IMPORTANT NOTE:**

Consult the attached wiring diagrams to identify wiring connections appropriate to the particular installation. Please note, some equipment such as GPS's and EFIS systems may be provided with multiple power inputs. For these installations the output of the IBBS must be connected to their "back-up" power input. These inputs are often identified as "Aircraft Power 2". For equipment having only a single power input terminal the IBBS pass-thru power function must be utilized. (This is typical of devices such as comm radios, transponders, autopilots, fuel pumps, and electronic ignitions). The IBBS system may be fed from a bus that remains active during engine starting, such as the master bus or it may be fed from an avionics bus that is switched off during engine starting.

2. Check that the total connected load (summed value of all four output wires of the IBBS) is less than the following product ratings:

IBBS-24v-3ah-CRT-V

5 amps maximum continuous current

10 amps peak for radio transmissions and transient loads*

*(30 seconds max duration)

3. Mount the IBBS system to structure in a suitable area of the aircraft utilizing the practices identified in AC 43.13-2A/1B. Ensure the mounting points and fasteners are suitable for the weight of the IBBS unit, consult the specifications for details. Do not mount the IBBS in the firewall forward area. Select an area that is accessible to allow for future battery servicing. The preferred operating temperature range of the system is -40 C° to 60 C°, the effective charging temperature range is -40 C° to 40 C° with extended charging times below 0 C°. Select an installation location that takes these temperatures into consideration.

Note: Rechargeable lithium cells are capable of generating hazardous emissions when defective or subject to physical or operational abuse. Although the IBBS system is protected from abusive failure conditions and includes a variety of fail-safe mechanisms, conditions may occur that could cause a Thermal Runaway (TR) event resulting in the venting of smoke or fumes and/or liquid from the designated vent port. The vent port must be routed to the bottom or side exterior of the aircraft via the vent hose.

Locate a suitable flat location measuring at least 3.3" x 12" in area, or in an existing avionics rack for mounting the IBBS enclosure.

The mounting area must meet one of the following requirements:

- i. A piece of 2024-T3 or T42 (alternate 6061-T6 or T62) sheet aluminum at least 0.050" thick material minimum.
Supported by at least 4 fasteners on at least two opposite edges with a maximum unsupported panel dimension of 12" in one direction and a 15" in the other direction.
- ii. Existing support brackets or rails that are at least 0.032" thick that are part of an avionics rack and form a flat surface for mounting.

Important mounting notes:

- a. The IBBS unit must be installed in the horizontal axis with respect to the mounting base plate of the unit.
- b. Ensure there is sufficient clearance around the IBBS unit for the wiring harness and vent hose, and ensure sufficient clearance to fuel tanks, fuel lines, oxygen lines or any other critical systems.
- c. Visually inspect the IBBS unit to ensure no damage has occurred to the unit prior to installation. Do not deform the unit enclosure by means such as drilling, bending or cutting of the enclosure. Do not open or modify the IBBS unit in any manner.

Utilize the base plate of the IBBS system to match drill mounting holes to the aircraft structure. See page 17 for mounting dimensions.

Fasten the IBBS unit to the aircraft structure utilizing 4 pcs of AN3 bolts or AN515R machine screws and mating lock nuts or nut plates.

Connect up to 48 inches of 3/8" I.D. vent hose to the vent port on the IBBS unit and secure with hose clamp. Vent hose and hose clamp are provided with the IBBS unit. The vent hose may be shortened. Do not extend beyond 48". Secure hose every 12" with MS21919-WH10 adel clamps (not provided). Do not kink hose, minimum bend radius for the vent hose is 2". Route the end of the hose to the bottom or side exterior of the aircraft.

4. Connect the aircraft wiring according to one of the wiring diagrams shown.

The IBBS must be powered from properly sized circuit breakers or fuses. Ensure the proper size wire is utilized for the input feed, output supply and ground connection.

Power Requirements: The IBBS has multiple power inputs.

Pin 5 receives power for charging the internal battery and bus voltage sensing for the switching logic within the IBBS unit. Pin 5 must be connected to an aircraft power bus. When the voltage on pin 5 falls below 11 volts the system automatically transfers the load current on the output pins to the internal back-up battery source. Pin 5 nominal current draw is 3.3 amps during charging.

Pin 4 provides power to an internal battery heater system utilized when the battery temperature is below 0 C°. The nominal current draw is 1.4 amps when the battery temperature is below 0 C°.

Pins 6,7,8 provide power that is passed-thru the IBBS unit to the loads connected to the output pins. These pass-thru power connections are optional and only required for systems that do not have multiple power inputs. These pins can also be used if it is desired to have redundant power paths feeding the connected loads. These pins are internally wired in parallel; it is recommended to populate all three pins; join the wires together and feed all of these inputs from the pass-thru power breaker. Note: these pins do not individually correspond to any particular output pin (12-15). The pass-thru breaker must be sized for the load that is connected to the IBBS outputs. The maximum combined load is 8 amps continuous, 12 amps peak for <30 seconds. If Pins 6,7,8 are used they must be connected to the same source of power as Pin 5.

Output Power connections:

The IBBS has four output pins, Pins 12,13,14,15. These pins provide power to the connected load. These four wires may be paralleled together for redundancy and load current sharing. Use 20 awg. wire for each pin. The total combined load for all four pins is 5 amps continuous, 10 amps peak.

5. The Back-up Power Master Switch must be utilized to turn the back-up battery system off when not in use. The back-up power master switch gives the pilot the ability to turn the back-up battery system off. In some installations this may be the only means to shut down the connected equipment.

6. The IBBS unit has a low voltage warning output, pin 3. This pin may be used to drive an LED indicator or to provide a digital signal to indicate the main input bus is in a low voltage condition. When the main input bus (connected to pin 5) falls below about 22 volts this output will drive to a low state. Maximum current sourced on this pin is 25 milliamps.

7. The IBBS unit has an internal battery monitor connection, pin 2. This pin allows the voltage state of the internal battery to be monitored with a separate volt meter or analog input of a monitor system. This pin will only report internal battery voltage when the unit is enabled by turning the Back-up Master switch ON. A fully charged battery back will indicate about 26-29.5 volts on this pin.

Important note: the meter utilized to measure pin 2 must have an input impedance >100k ohms otherwise it will load down pin 2 and provide an artificially low voltage reading.

When used with the following EFIS systems wire pin 2 to the Volts2 input of the EFIS or engine monitor as follows:

Manufacturer/model	Volts 2 input location
Garmin G3x system GEA 24	J244, Pin 28
Advanced Flight Systems 5000 series:	Expansion Port Pin 13

8. Complete the installation of the wiring harness and connector prior to attaching the connector to the IBBS product. It is essential to ensure the wires do not inadvertently short together during installation. Remember, the IBBS pack is a back-up source of power and is ready to deliver output power even when the aircraft electrical system is in the off state.

9. When using the IBBS product to provide back-up power to an electronic ignition system it MUST be used to back-up one and only one electronic ignition module. Do not use one IBBS to back up both electronic ignition modules in a dual electronic ignition system. Follow the instructions per the electronic ignition manufacture. Do not connect any other loads to the IBBS when using the IBBS to power an electronic ignition module. Do not use the IBBS system to back-up a dual ignition system having only a single power input. Do not use a single IBBS system to back-up two electronic ignition systems.

General Product Information:

The Charging System:

The IBBS automatically maintains its internal battery pack. The internal charging circuit monitors the state of the internal battery and recharges it as necessary when the aircraft is operational. The aircraft's DC supply bus must reach at least 26.4 volts before the IBBS will permit a charge cycle to begin. The input current for battery charging is 1.9 amps. (charging only occurs when the aircraft alternator is running and has available capacity)

If the internal battery is fully discharged for any reason it may require up to 90 minutes of recharge time with the normal aircraft bus on. NOTE: Do not attempt to recharge the IBBS product by using an external battery charger directly connected to the input of the IBBS. Do not attempt to utilize battery tender chargers for other types of lead acid battery chargers directly connected to the IBBS inputs. Battery chargers typically provide pulsating voltages that may damage the IBBS product if the system is not connected to a typical primary aircraft battery. Also note, you cannot use a DMM connected to pins 4,5 to measure any meaningful value. Battery voltage may be read on pin 2 or any of the outputs pins 12-15 with the IBBS system enabled via the grounding of pin 1. Note: recharging of battery is linear with respect to time. For example, under nominal conditions a recharge period of 1 hour will provide 2/3 of rated product capacity.

Recharge time at normal temperatures: 0C° to 40 C° 90 minutes nominal
Recharge time at low temperatures: -18C° to 0 C° 90 minutes nominal + 30 minutes preheat
-45 C° to -18C° 90 minutes nominal + 60 minutes preheat

Back-up Power Master Switch:

The IBBS has one input switch connection as identified in the wiring diagrams: Back-up Power Master. This switch enables back-up power from the IBBS system to be available on the output wires when power on the normal aircraft bus falls below about 22 volts. Pin 1 is pulled to ground when the back-up master switch is turned on, this enables the IBBS system.

If the back-up power master switch is enabled and normal aircraft power falls below 22 volts, then the internal back-up battery will be connected to the outputs and be utilized to supply back-up power to the connected load.

If the normal aircraft power bus is above 22 volts, then the outputs are energized with normal aircraft power (if the pass thru-power connections are utilized) and the back-up battery remains off-line. This operation occurs regardless of the state of the Back-up Power Master switch. This allows for automatic pass through of power during normal operation.

Ground Based Recharging:

To accomplish ground-based charging, connect an approved battery charger or DC power source (set to 28 volts) to the main aircraft battery and energize the main aircraft power bus by turning on the aircraft master switch, leave all other aircraft loads in their off state.

Note, the ground base source of power must be capable of supplying the load current of all devices that can not be turned off in this nominal state, plus the 1.9 amps of IBBS recharge current. Leave the ground-based charging system connected and powered until the IBBS system completes its recharge cycle of its internal battery, see Charging System detail above for battery charging times. If voltage monitoring of pin 2 of the IBBS is available a peak charging voltage of 29-30 volts will be observed as the battery reaches full capacity.

Alternately, a ground-based charger is available from TCW Technologies LLC., model # IBBS-24v-CHARGER-LI-FE. This charger may be used for recharging the IBBS unit as well as keeping it topped off during long term product storage. (9 months or longer)

Battery Capacity:

The IBBS provides a capacity of 3 amp-hours at 24 volts for when the system is fully charged and operated at 23 C°. Depending on various conditions including operating and storage temperature and age of the battery pack, the capacity of the system will vary. With a fully charged battery, the following average performance can be expected in terms of operating duration. The operating duration is for output voltage down to 20 volts (end point voltage).

Total connected load	Duration	Capacity
1.5 amps	120 minutes	3 amp-hrs
3.0 amps	60 minutes	3 amp-hrs
5.0 amps	32 minutes	2.6 amp-hrs

Capacity at various temperatures:

- +70 C° 95% of effective nominal capacity
- 18 C° 75% of effective nominal capacity
- 30 C° 70% of effective nominal capacity
- 45 C° 45% of effective nominal capacity

Servicing:

The internal battery in the IBBS system is replaceable; however, the IBBS product must be returned to TCW Technologies, LLC. for this service. The unit must be replaced with the same Part Number unit or later FAA approved revision. Battery life depends strongly on many factors including operating and storage temperature, number of discharge cycles and depth of discharge. The battery capacity should be checked at least annually for suitable back-up power operation of the connected equipment. When the battery capacity no longer meets the operating criteria of the aircraft it must be replaced. Contact TCW Technologies, LLC. regarding battery replacement.

Storage beyond 9 months:

If the IBBS unit is stored without connection to an in-service aircraft for a period greater than 9 months, it must be connected to a source of DC power to maintain the battery's charge. Allow for a self-discharge rate of approximately 5% capacity (in amp-hrs) per/month for storage temperatures between 0C°– 50C°. Only connections to the ground terminal and the main power terminal are required. Connect Pin 5 (main power) and Pin 9 (ground) of the IBBS to a source of regulated DC power at 27-29 volts with a current capability of at least 1.9 amps to accomplish full recharging. Charger model IBBS-CHARGER-LiFe-24v is available from TCW Technologies, LLC. to simplify this activity.

Upon completion of installation:

The required back-up operating time for the connected equipment should be recorded in the aircraft logbook with follow-up entries confirming the annual testing results that indicate that the required operating time is satisfied.

Normal Product Operation:

For normal operation, the following is the recommend operating procedure. These operating procedures are to be added to the aircraft operating checklist for standard procedures.

Pre-flight Inspection

If the IBBS unit is mounted in a baggage area, ensure all cargo is loaded and secured at least 1" away from the IBBS unit.

Start-up Procedure:

- 1) Prior to turning on the Aircraft Master Switch, turn ON the Back-up Power master switch.
- 2) Turn on any equipment that derives back-up power from the IBBS product.
- 3) Ensure the connected equipment successfully boots-up and is operating properly. (During this period of time the equipment is running off of the back-up battery within the IBBS product. This test ensures the transfer circuit and back-up battery are properly working)
- 4) Turn on the Aircraft Master Switch; ensure the connected equipment remains energized.
(If a separate avionics bus is utilized, this may need to be turned ON to continue the operation of equipment connected to the IBBS output.)
- 5) Start and operate the aircraft according to normal operating procedures.

Shut-down Procedure:

- 1) Shut down the aircraft engine using normal procedures.
- 2) Shut down the Aircraft Master Switch
- 3) Verify that the equipment that derives back-up power from the IBBS remains ON
- 4) Turn-off the Back-up Power Master switch, ensure that equipment powers down.
(This procedure further ensures the operation of the transfer circuit within the IBBS.)

Emergency Product Operations: during loss of main aircraft electrical power

For emergency operation, the following is the recommended operating procedure and is the basis for a flight manual supplement.

- 1) Operate the Aircraft Master Power Switch per the Emergency Procedure checklist already established for the aircraft.
- 2) Ensure the Back-up Master Switch is in the ON position.
- 3) Land aircraft as soon as practical to resolve the loss of main electrical power.

Instructions for Continued Airworthiness

Inspection and endurance testing procedures: All applications except electronic ignition systems

On at least an annual basis the inspection of the IBBS system and the endurance capability of the IBBS system shall be confirmed and compared against the back-up endurance required for the connected equipment.

As an alternate to these tests, the IBBS unit may be returned to TCW Technologies for a loaded endurance test, contact TCW Technologies LLC. for details.

Inspection:

Visually inspect the IBBS unit and its surrounding location to ensure there has not been damaged from: environmental or physical impacts such as mechanical shock, vibration, heat and possible abuses encountered during storage or utilization.

If the unit has been damaged in any way or does not comply with the following endurance test, the unit must be replaced with the same Part Number unit or later FAA approved revision. The use of alternate models will require a new FAA installation approval. The internal battery is not field replaceable. The IBBS unit must be returned to TCW Technologies, LLC for all repair and servicing requirements.

Endurance testing:

- 1) Turn off the Aircraft Master Switch
- 2) Turn on the Back-up Power Master Switch
- 3) Turn on all equipment connected to and supplied with back-up power from the IBBS product.
- 4) Measure and record at least the following information: The time until the first piece of connected equipment no longer functions or the time until the output of back-up power supply voltage drops to 9.5 volts. Discontinue the test when the back-up battery voltage falls below 9.5 volts.
- 5) After completing the endurance test, recharge the IBBS product by operating the system with the Aircraft Master Switch in the ON position for up to two hours. This may be done by operating the aircraft in conditions known to not require back-up power or by powering the aircraft system on a suitable ground power source as described in the section: Ground Base Recharging.
- 6) Record the results of the endurance testing in the aircraft logbook.
- 7) If the IBBS no longer meets the endurance testing requirement, the back-up battery may need replacement. Contact TCW Technologies, LLC. for servicing.

Instructions for Continued Airworthiness

Inspection and endurance testing procedures: Electronic Ignition System Back-up

On at least an annual basis the inspection of the IBBS system and the endurance capability of the IBBS system shall be confirmed and compared against the back-up endurance required for the connected equipment.

As an alternate to these tests, the IBBS unit may be returned to TCW Technologies for a loaded endurance test, contact TCW Technologies LLC. for details.

Inspection:

Visually inspect the IBBS unit and its surrounding location to ensure there has not been damaged from: environmental or physical impacts such as mechanical shock, vibration, heat and possible abuses encountered during storage or utilization.

If the unit has been damaged in any way or does not comply with the following endurance test, the unit must be replaced with the same Part Number unit or later FAA approved revision. The use of alternate models will require a new FAA installation approval. The internal battery is not field replaceable. The IBBS unit must be returned to TCW Technologies, LLC for all repair and servicing requirements.

Endurance testing:

COMPLETE THESE STEPS IN ORDER Perform these tests with the aircraft properly secured on the ground, these are not flight test procedures.

- 1) Start the aircraft using normal starting procedures, including turning ON the Back-up Master switch
- 2) Select engine operation based on the use of only the electronic ignition module provided with back-up battery power.
- 3) PULL the circuit breaker feeding pins 4,5 of the IBBS system, confirm engine continues to run.
- 4) PULL the circuit breaker feeding pins 6,7,8 of the IBBS, confirm the engine continues to run.
- 5) Perform the following; test A or test B:

Test A: abbreviated battery test:

Monitor engine operation and voltmeter reading on any of pin 12,13,14,15, the back-up power output. Confirm back-up voltage begins above 13 volts and for a period of 15

minutes remains above 12.5 volts. If these requirements are met the battery pack is satisfactory.

Test B: full endurance test:

Operate the engine on the electronic ignition system for the required minimum run-time requirement (at least 30 minutes), monitor the back-up battery voltage on the voltmeter connected to an output pin, the battery voltage must remain above 11 volts for the duration of the test. If this requirement is met the battery pack is satisfactory.

- 6) Turn off the Back-up Master Switch and confirm that the engine turns off.
- 7) If all these tests pass, the IBBS system is functioning properly, record the results in the aircraft logbook.
- 8) If any of these tests fail, the IBBS system is not functioning properly and corrective action must take place. If the IBBS no longer meets the endurance testing requirement, the back-up battery may need replacement or service. Contact TCW Technologies, LLC. for servicing.
- 9) Return all pullable breakers to the normal ON position and ensure aircraft engine is properly returned to the off position by following normal run and shut down procedures.
- 10) After completing these tests, recharge the IBBS product by operating the system normally for up to 1.5 hours. This may be accomplished by operating the aircraft in conditions known to not require back-up power or by powering the aircraft system on a suitable ground power source as described in the section: Ground Base Recharging.

Service Life:

Expected service life for the internal battery pack is greater than 500 discharge cycles. Operational performance must be checked at least annually per the requirements for instructions for continued airworthiness listed above. At the end of 72 months of service installation the internal battery pack must be replaced. If the unit has been damaged in any way, the unit must be replaced with the same Part Number unit or later FAA approved revision. The use of alternate models will require a new FAA installation approval. The internal battery is not field replaceable. The IBBS unit must be returned to TCW Technologies, LLC for all repair and servicing requirements.

SPECIFICATIONS: IBBS-24v-3ah-CRT-V

Certification:	TSO-C179(b) class A-3B (see https://www.tcwtech.com/wp-content/uploads/2022/01/TSO-C179b-testing-statement_IBBS-CRT.pdf for TSO testing data information)
Input Voltage*	26.4-32 volts DC for battery charging
Transition Voltage**	21-23 volts
Input Current:	1.9 amps on main input for charging 0.7 amps for battery heating at low temps
Pass-thru Current:	5 amps continuous, 10 amps peak (30 seconds)
Output Voltage:	22-29 volts DC during back-up operation
Output Current:	5 amps continuous 10 amps peak for radio transmissions and transient load (30 second duration max)
Capacity (23 C°):	3 amp-hrs @ 24 volts @ 3 amp load current 2.6 amp-hrs @ 24 volts @ 5 amp load current
Battery:	Internal sealed Li-Fe-PO4
Charger:	Integral high performance fast charger
Surge Protection:	34 volt active clamp, 1500w 10/1000uS waveform
Wiring:	15 pin male D-sub on product.
Enclosure:	Aluminum 11.92 x 3.3 x 3.2 inches
Weight:	4.25 lb
Temperature range:	Operating: -40 C° to 60 C° Charging: -40 C° to 40 C°
Connector:	Standard density 15 pin male D-sub on product

Note: Input voltages in excess of 35 volts or reverse polarity may damage unit

*minimum input voltage to start a charge cycle is 26.4 volts, this ensures aircraft alternator is running prior to starting a charge cycle.

**transition voltage is the voltage level on the input that causes the system to provide output power via the internal back-up battery

Functional performance

Certification:	FAA TSO-C179b class A-3B
Performance Qualification:	RTCA DO-311a Minimum Operational Performance Standards for Rechargeable Lithium Battery Systems
Environmental Qualification:	RTCA DO-160 F,G B2BBB[SCU2F&F1]EYXXFSZB(IX)XXXXAB(ZC)[TT]MA3XXXXXXAX
Power Input	28 volts nominal, 1.9 amps charging, 0.7 amp heating
Power Output	24.0 volts nominal @ 5 amps continuous
Battery Capacity	3.0 amp-hrs @ 1C rate @ 25C°
Maintenance	Perform annual capacity check

ENVIRONMENTAL QUALIFICATION STATEMENT

NOMENCLATURE: Integrated Back-up Battery System

MODEL/PART NUMBER: IBBS-24V-3AH-CRT -V

MANUFACTURES SPECIFICATIONS:

QUALIFICATION STANDARD:

TSO NUMBER: C179b class A-3B

Minimum Performance Specification:

IBBS product specification per 720.0012

RTCA Do-160(f), dated Dec 6, 2007

RTCA Do-160(g), dated Dec 8, 2007 (*)

CONDITIONS	SECTION	DESCRIPTION OF TEST
Temperature and Altitude	4	Category B2
Low Temperature	4.5.1	Operating Low Temp = -45 C°
High Temperature	4.5.3	Operating High Temp = +70C°
Decompression	4.6.2	Altitude = +55,000ft.
Overpressure	4.6.3	Altitude= -15,000ft.
temp variation	5	Category B
humidity	6	Category B
operational shock*	7	Category B
vibration*	8	Cat S-C, Cat U2-F&F1
explosion	9	Category E
waterproofness	10	Category Y
fluid susceptibility	11	Category X
sand and dust	12	Category X
fungus *	13	Category F
salt fog salt spray *	14	Category S
magnetic effect	15	Category Z
power input	16	Category B(IX)
voltage spike	17	Category A
audio freq susceptibility	18	Category B
induced sig susceptibility	19	Category ZC
Spikes induced into interconnect cables	19.3.4	Category CC
RF susceptibility*	20	Category TT
Emission of RF energy	21	Category M
lightning environment *	22	Category A3XXXX level 3
lightning direct	23	Category X
icing	24	Category X
ESD	25	Category A
flammability	26	Category X

RTCA DO-160 F,G

B2BBB[SCU2F&F1]EYXXFSZB(IX)XXXXAB(ZC)[TT]MA3XXXXXXAX

Wiring connector detail:

Male on IBBS unit
Female on aircraft wiring harness

View from back of connector on harness

15 pin Male Dsub on unit

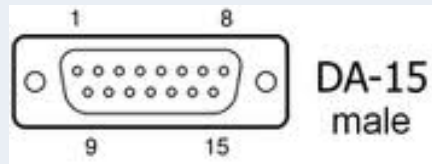

Pin #	Function
1	Enable- backup switch
2	Batt-info
3	Low Volt Warn
4	PWR + in, charge, sensing
5	PWR + in, charge, sensing
6	Pwr +, pass-thru input
7	Pwr +, pass-thru input
8	Pwr +, pass-thru input
9	Ground
10	Ground
11	Ground
12	Output
13	Output
14	Output
15	Output

IBBS unit mounting footprint

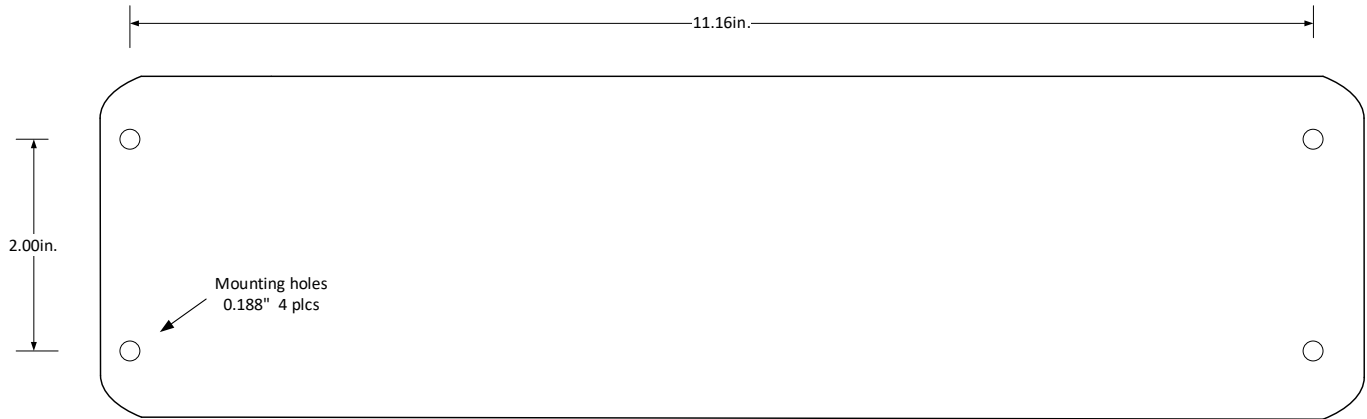

All dimensions in inches
IBBS unit height = 3.2"
C.G at center of all axis

General Wiring Diagram

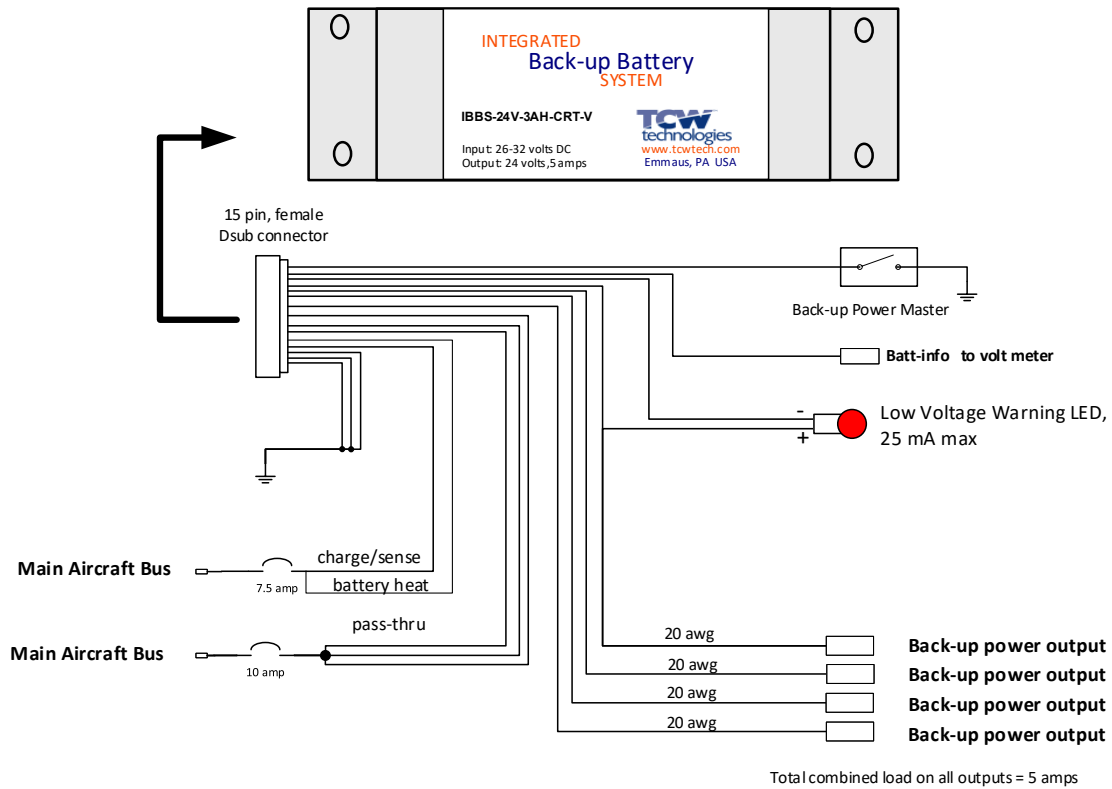

15 pin Male Dsub on unit

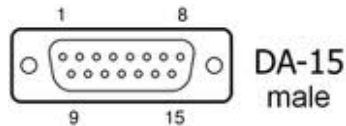

Pin #	Function	Pin #	Function
1	Back-up master switch	9	Ground
2	Batt-info	10	Ground
3	Low Volt Warn	11	Ground
4	PWR + in, battery heater	12	Output
5	PWR + in, charge, sensing	13	Output
6	Pwr +, pass-thru input	14	Output
7	Pwr +, pass-thru input	15	Output
8	Pwr +, pass-thru input		

Wiring Diagram IBBS-24v-3ah-CRT-V

Equipment without Back-up Power Input

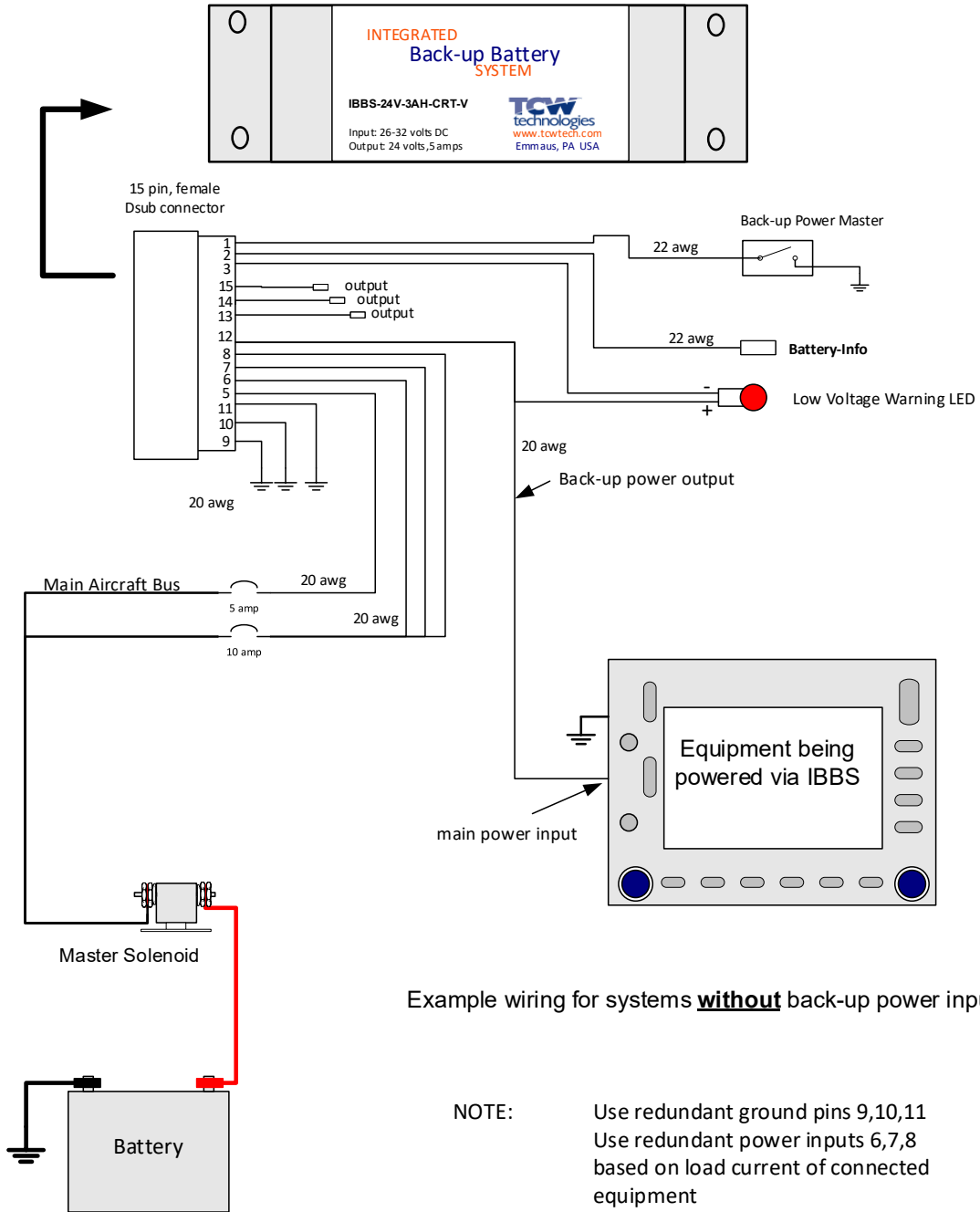

Wiring Diagram IBBS-24v-3ah-CRT-V

Equipment with Back-up Power Input

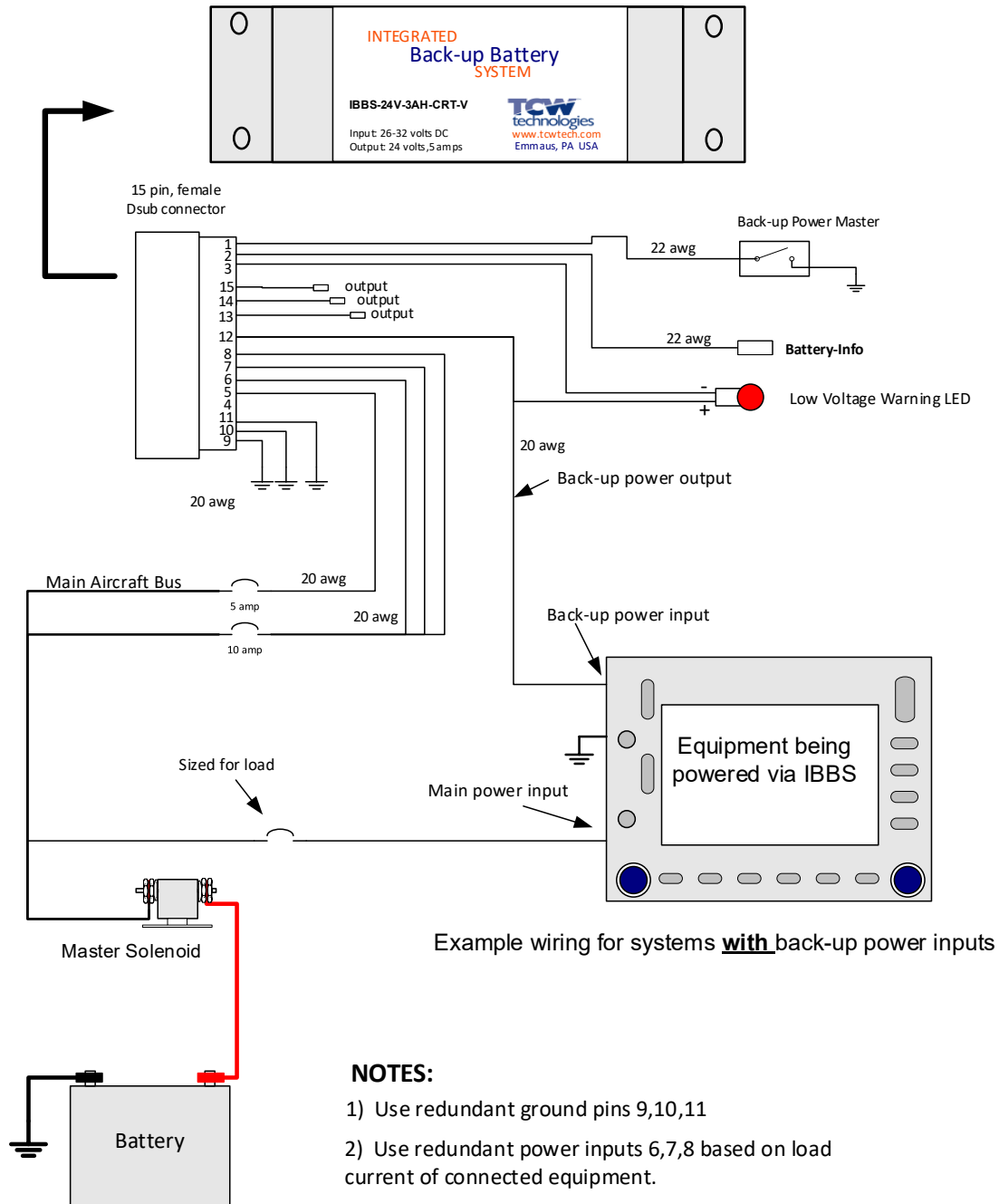

Example wiring for systems with back-up power inputs

NOTES:

- 1) Use redundant ground pins 9,10,11
- 2) Use redundant power inputs 6,7,8 based on load current of connected equipment.

Service and Support information:

610-928-3420
www.tcwtech.com
 email: support@tcwtech.com

TCW Technologies, LLC.
 2955 Main Road East
 Emmaus, PA 18049

TCW Technologies, LLC.

During the first 12 months from the date of purchase and subject to the conditions hereinafter set forth, TCW Technologies, LLC. (TCW) will repair or replace to the original user or consumer any portion of your new TCW product which proves defective due to defective materials or workmanship of TCW. Contact TCW Technologies for warranty service. TCW shall have and possess the sole right and option to determine whether to repair or replace defective equipment, parts or components. Damage due to equipment, environment or conditions beyond the control of TCW Technologies are NOT COVERED BY THIS WARRANTY.

LABOR, COSTS: TCW shall IN NO EVENT be responsible or liable for the cost of field labor or other charges incurred by any customer in removing and/or reaffixing any TCW product, part or component thereof.

THIS WARRANTY WILL NOT APPLY: (a) to defects or malfunctions resulting from failure to properly install, operate or maintain the unit in accordance with printed instructions provided; (b) to failures resulting from abuse, accident, or negligence; (c) to normal maintenance services and the parts used in connection with such service; (d) to units which are not installed in accordance good trade practices; or (e) to unit used for purposes other than for what it was designed and manufactured.

RETURN OR REPLACED COMPONENTS: any item to be replaced under this Warranty must be returned to TCW Technologies in Emmaus, PA, or such place as TCW may designate, freight prepaid.

PRODUCT IMPROVEMENTS: TCW reserves the right to change or improve its products or any portions thereof without being obligated to provide such a change or improvement for units sold and /or shipped prior to such change or improvement.

WARRANTY EXCLUSIONS: as to any specific TCW product, after the expiration of the time period of the warranty applicable thereto as set forth above. THERE WILL BE NO WARRANTIES, INCLUDING ANY IMPLIED WARRANTIES OR MERCHANTABILITY OR FITNESS FOR ANY PARTICULAR PURPOSE.

Some states do not allow limitations on how long an implied warranty lasts, so the above limitation may not apply to you. No warranties or representations at any time made by any representative of TCW shall vary or expand the provisions hereof.

LIABILITY LIMITATION: IN NO EVENT SHALL TCW OR ITS AFFILIATES BE LIABLE OR RESPONSIBLE FOR CONSEQUENTIAL, INCIDENTAL OR SPECIAL DAMAGES RESULTING FROM OR RELATED IN ANY MANNER TO ANY TCW PRODUCT OR PARTS THEREOF. THE SUITABILITY OF USE OF THE TCW TECHNOLOGIES, LLC. PRODUCT IS TO BE DETERMINED BY THE AIRCRAFT BUILDER.

Some states do not allow the exclusion or limitation of incidental or consequential damages, so the above limitation or exclusion may not apply to you.

This Warranty gives you specific legal rights and you may also have other rights which vary from state to state. In the absence of other suitable proof of this installation date, the effective date of this Warranty will be based upon the date of manufacture plus one year. Direct All Notices To: Warranty and Product Service Department, TCW Technologies, 2955 Main Road East. Emmaus, PA 18049